

# MTP50-A

NDIR CO2 gas Dual Channel Sensor Module

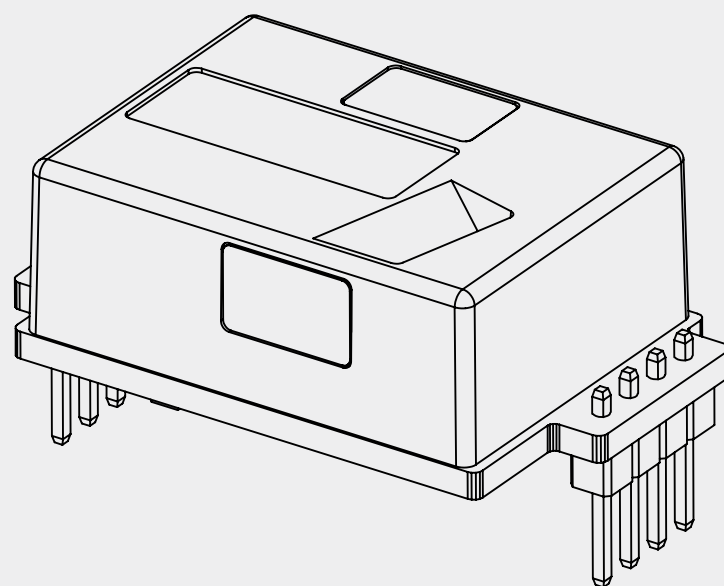

## S P E C I F I C A T I O N

# MTP50-A

## NDIR CO2 Sensor Module

### ◆ Appearances and Dimensions

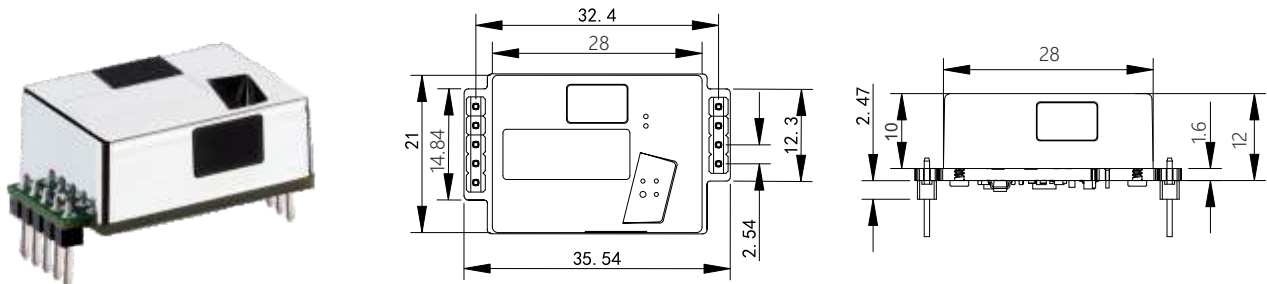

### ◆ Specifications

MTP50-A	
Target Gas	CO <sub>2</sub>
Operating Principle	NDIR
Measurement Range	400ppm---5000ppm
Measurement Interval	2s
Accuracy	± (50ppm + 5% of reading )
Response Time	T90 time is 90s
Operating Temperature	0-50°C
Operating Humidity	0-90% RH non condensed
Storage Temperature	-20°C---60°C
Dimensions	35.6X21.2X12.7mm(max dimensions)
Power Supply	4.2V---5.5V
Power Consumption	300mA peak, 4mA normal, 13mA average
Life Expectancy	10 years+
Serial Communication	Uart /IIC
PWM Output	Period: 1004ms, Pulse: 2ms-1002ms(0---5000ppm)
Alarm Output	>1000ppm output to 1, <800ppm output to 0, open-drain output with pull-up resistor, the pin cannot sink any current
Self Calibration Cycle	Initial time is 24 hours, later is 7 days

### Absolute Maximum Ratings

Parameter	Minimum	Maximum	Units
Ambient Storage Temperature	-40	85	°C
Maximum Voltage Range	-0.3	5.5	V
Maximum Output Current from Active Output Pin	-25	+25	mA
Maximum Current on Input	-5	+5	uA
Maximum Load Voltage on UART Pin	-0.3	3.5	V

**MTP50-A**  
**NDIR CO2 Sensor Module**

◆ PIN Assignment

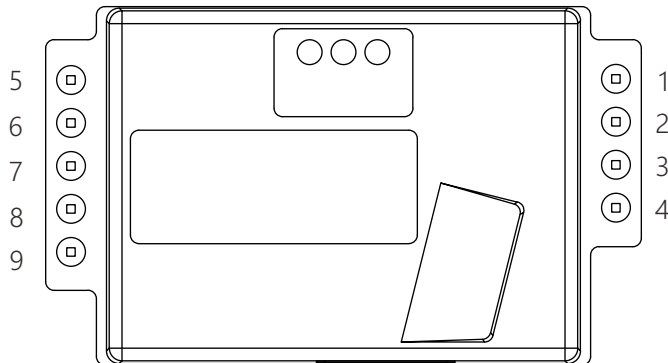

NO.	Name
1	VIN: 4.2V---5.5V
2	GND
3	Alarm-OC
4	PWM
5	VCC-Out:3.3V
6	Host-TX/IIC-SDA
7	Host-RX/IIC-SCL
8	R/T
9	bCAL-in

◆ Pin definition

Pin name	Pin function description	Pin Electrical Characteristics
<b>power pin</b>		
GND(Pin 2 )	Negative terminal of power supply	
VIN (Pin1 )	<b>Positive power supply</b>	With anti-reverse protection, input voltage range: 4.2V-5.5V
VCC-Out (Pin5)	The internal LDO output of the sensor is usually 3.3V±2%. Generally used for serial communication level conversion.	Output voltage: 3.3V±2%, no overcurrent protection, maximum output current: 6mA
<b>Communication pin</b>		
Host-TX (Pin6)/IIC-SDA	The TX pin of the UART of the host system, usually the TX of the client MCU, or the SDA of the IIC function	Usually the communication level is 3.3V, and there is a 1K series current limiting resistor inside. When used as an IIC function, the pin is configured as an open-drain mode, and an external pull-up resistor is required for use.
Host-RX (Pin7)/IIC-SCL	The RX pin of the UART of the host system, usually the RX of the client MCU, or the SCL of the IIC function	Usually the communication level is 3.3V, and there is a 1K series current limiting resistor inside. When used as an IIC function, the pin is configured as an open-drain mode, and an external pull-up resistor is required for use.
<b>Function pin</b>		
PWM(Pin4 )	PWM function for outputting CO2 concentration.	The pin is in push-pull output mode, and the output PWM period is 1004ms.
Alarm-OC (Pin3)	Alarm function, the pin is open-drain output mode. When the measured concentration > 1000ppm, the output of this pin is high, when the concentration is < 800ppm, the output of this pin is low.	The pin is in open-drain output mode and cannot directly drive a load. An external pull-up resistor is required.
R/T (Pin8)	This pin has two functions: 1. As RS485 direction control pin. This pin is Open-drain output mode, can be directly connected to RS485 chip The direction enable pin needs to be connected with an external pull-up resistor. This time module Pin6 and Pin7 are UART functions. 2. UART/IIC function selection pin. This pin is in grounding before power-on (grounding after power-on is invalid), Pin6 and Pin7 of the group are IIC functions.	When the pin is powered on, it is an input mode with pull-up, which can be suspended or grounded. When used as the RS485 direction enable pin, it is an open-drain output mode, and an external pull-up resistor is required.
bCAL-in (Pin9)	Manual Calibration Control Pins	When the pin is powered on, it is an input mode with a pull-up resistor

**MTP50-A**  
**NDIR CO2 Sensor Module**

◆ Calibration function

The MTP50 module is a precision optical module. After leaving the factory, due to various reasons such as transportation, installation, and welding, it will cause a certain drift in the measurement of the module, resulting in poor accuracy. The module has a built-in self-calibration algorithm, which can automatically correct the measurement error periodically, so that the module can always maintain a relatively good measurement accuracy. The module self-calibration cycle defaults to 7 days (168 hours), which can be adjusted by command (24 hours to 720 hours). In order to make the module adjust the accuracy faster, the module will complete a self-calibration within 24 hours of power-on, and then perform periodic self-calibration according to the set cycle. In order to ensure the measurement accuracy of the sensor after calibration, please ensure that within 24 hours of power-on and within 7 days of continuous operation, the concentration of CO2 in the working environment of the sensor can be close to the outdoor atmospheric level for at least several hours.

◆ Alarm function

The MTP50 module supports the alarm output function, which is output through the Alarm-OC pin. When the measured CO2 concentration value > 1000PPM, the Alarm-OC pin outputs a high level.

When the measured CO2 concentration value is <800PPM, the Alarm-OC pin outputs a low level. Note that the Alarm-OC pin is configured as an open-drain output mode, and an external pull-up resistor is required for use.

If an error occurs in the module, the Alarm-OC pin will remain high. Refer to the usage method as shown on the right

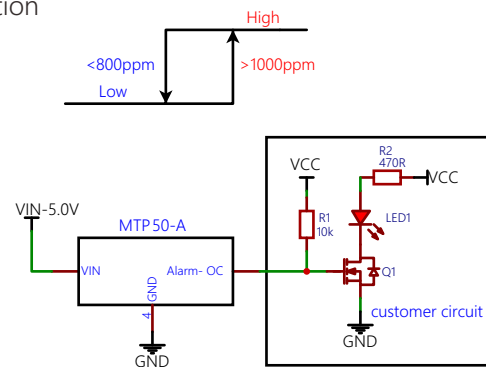

◆ Protocol

**Serial communication**

The baud rate of the serial communication is 9600bps  
 Serial port communication package definition:

1. Protocol format

Frame format description:

byte	length	description
frame header	2	Fixed to 0x42, 0x4D
command byte	1	command definition or sensor type definition
command byte	2	specific command word
data length	2	big endian
data	n	big endian
checksum	2	Sum of all bytes from the frame header to the last byte of data

The following protocol description is applicable to the gas sensor series, the instruction byte is: 0xA0.

Command Byte Description

command word	description
0x0001	Set air pressure parameters (internal default air pressure is 1013.0hPa)
0x0002	Read the current barometric pressure value
0x0003	Read gas concentration value
0x0004	Single point correction function (with reference concentration)
0x0005	Single point correction read status
0x0006	Disable or enable self-calibration
0x0007	Read self-calibration status
0x0008	Read self-calibration period (hours)
0x0009	Set self-calibration period (hours)

# MTP50-A

## NDIR CO2 Sensor Module

### 2. Basic Control Protocol

function name		frame header	command byte	command byte	data length	data	checksum
Set barometric parameters	MCU sends	0x42 0x4d	0xA0	0x0001	0x00 0x02	Atmospheric pressure value range is 700--1100 (16bit integer)	checksum
	module return	0x42 0x4d	0xA0	0x0001	0x00 0x00		checksum
Read the current air pressure value	MCU sends	0x42 0x4d	0xA0	0x0002	0x00 0x00		checksum
	module return	0x42 0x4d	0xA0	0x0002	0x00 0x02	Atmospheric pressure value (16bit integer)	checksum
Read the current concentration value	MCU sends	0x42 0x4d	0xA0	0x0003	0x00 0x00		checksum
	module return	0x42 0x4d	0xA0	0x0003	0x00 0x05	Gas concentration value (32bit integer) and data valid identification (8bit) 0x00: valid; 0xFF: data unavailable;	checksum
Single point correction function (with reference concentration)	MCU sends	0x42 0x4d	0xA0	0x0004	0x00 0x04	The range of reference concentration is 400--5000 (32bit integer)	checksum
	module return	0x42 0x4d	0xA0	0x0004	0x00 0x01	0x01: Indicates that calibration starts 0xFF: Indicates calibration error	checksum
Read single point correction status	MCU sends	0x42 0x4d	0xA0	0x0005	0x00 0x00		checksum
	module return	0x42 0x4d	0xA0	0x0005	0x00 0x01	0x00: Indicates that the calibration is completed 0x01: Indicates that the calibration is still in progress	checksum
Enable or disable self-calibration	MCU sends	0x42 0x4d	0xA0	0x0006	0x00 0x01	0x00: enable self-calibration 0xff: disable self-calibration	checksum
	module return	0x42 0x4d	0xA0	0x0006	0x00 0x00		checksum
Read self-calibration status	MCU sends	0x42 0x4d	0xA0	0x0007	0x00 0x00		checksum
	module return	0x42 0x4d	0xA0	0x0007	0x00 0x01	0x00: enable self-calibration 0xff: disable self-calibration	checksum
Read self-calibration period	MCU sends	0x42 0x4d	0xA0	0x0008	0x00 0x00		checksum
	module return	0x42 0x4d	0xA0	0x0008	0x00 0x02	Self-calibration cycle range: 24--720h	checksum
Set self-calibration period	MCU sends	0x42 0x4d	0xA0	0x0009	0x00 0x02	Self-calibration cycle range: 24--720h	checksum
	module return	0x42 0x4d	0xA0	0x0009	0x00 0x01	00: correct operation; 01: the input data is less than 24h, not acceptable; 02: the input data is greater than 720h, not acceptable	checksum

### 3. Application example

#### ① Set barometric parameters

Send: 0x42 0x4D 0xA0 0x00 0x01 0x00 0x02 0x03 0xF5 0x02 0x2A

Device	Phase	Data	Description	Cmd. Phase. ofs(rep)
43	OUT	42 4d a0 00 01 00 02 03 f5 02 2a	BM . . . . . *	1. 1. 0
43	IN	42 4d a0 00 01 00 00 01 30	BM . . . . . 0	2. 1. 0

0x03F5 is the hexadecimal of 1013;

#### ② Read the current air pressure value

Send: 0x42 0x4D 0xA0 0x00 0x02 0x00 0x00 0x01 0x31

Device	Phase	Data	Description	Cmd. Phase. ofs(rep)
43	OUT	42 4d a0 00 02 00 00 01 31	BM . . . . . 1	1. 1. 0
43	IN	42 4d a0 00 02 00 02 03 f5 02 2b	BM . . . . . +	2. 1. 0

## MTP50-A

### NDIR CO2 Sensor Module

③Read the gas concentration value

Send: 0x42 0x4D 0xA0 0x00 0x03 0x00 0x00 0x01 0x32

The data valid bit is 0xFF, and the data is not available:

Device	Phase	Data	Description	Cmd. Phase. Ofc(rep)
43	OUT	42 4d a0 00 03 00 00 01 32	BM .....2	1 1 0
43	IN	42 4d a0 00 03 00 05 00 00 00 00 ff 02 36	BM .....6	2 1 0

### ◆ IIC instruction analysis

The module works in IIC slave mode and can be connected to an external MCU. The module contains a pull-up resistor inside.

The slave address of the module device is: 0x32 (7-bit address)

The write operation address of the module is: 0x64

The read operation address of the module is: 0x65

Host sending timing:

- 1.send start signal
- 2.send address write (slave address + R/W = 0x64) and check response
- 3.send a read command (0x03) and check the response
- 4.send stop signal
- 5.send start signal
- 6.send address read (slave address+R/W(1)=0x65) and check response
- 7.read 3 bytes from the module and send an acknowledgment
- 8.send stop signal

The received 3-byte data is described as follows:

Co2 concentration		data valid byte
concentration high byte	concentration low byte	0x00/0xFF

Notice:

Co2 concentration = high byte in CO2 concentration \* 256 + low concentration byte

Data valid byte, 0x00 means the data is valid, 0xFF means the data is invalid

### ◆ Detailed explanation of PWM function

The period of PWM is 1004ms

High level output for 2ms in the initial stage

Middle cycle 1000ms

Low level output for 2ms at the end stage

The calculation formula for obtaining the current CO2 concentration value through PWM:

$$C_{ppm} = 5000 * (TH - 2ms) / (TH + TL - 4ms)$$

Cppm is the calculated CO2 concentration value, the unit is ppm

TH is the time when the output is high in one output cycle

TL is the time when the output is low in one output cycle

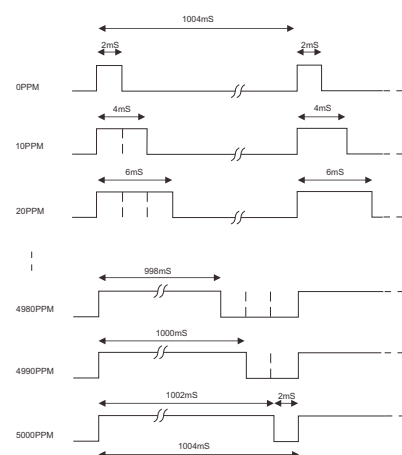

## MTP50-A

NDIR CO2 Sensor Module

## ◆ Number Description

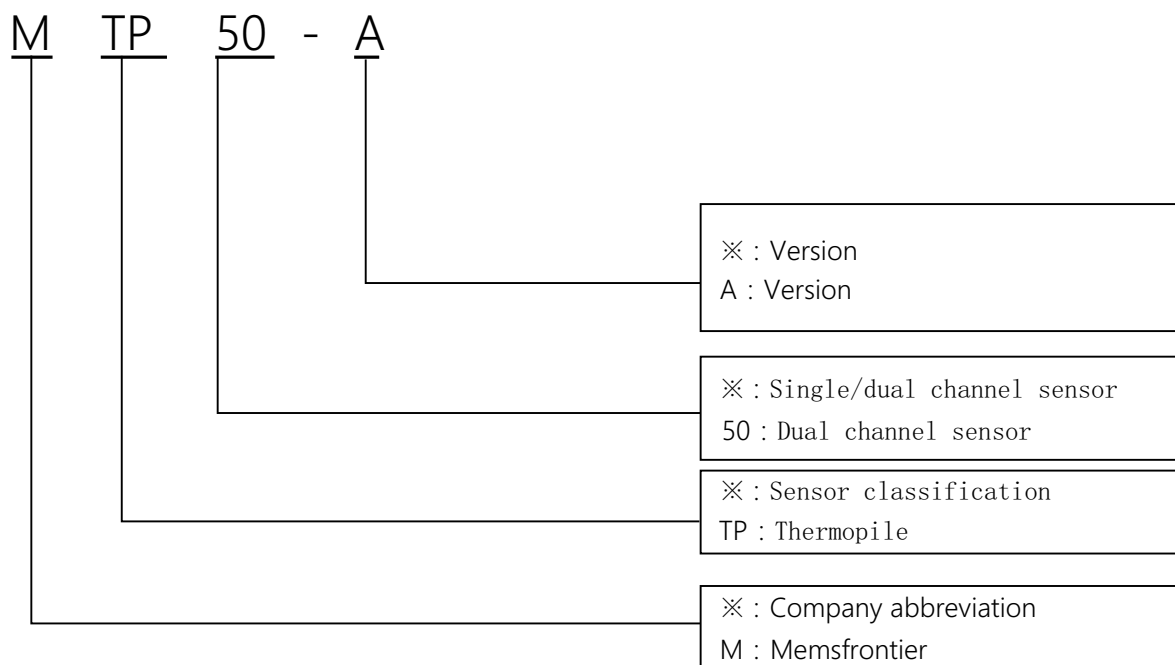

**MTP50-A**  
 NDIR CO2 Sensor Module

◆ Packing

Quantity per plate	Packing layers	Packing Quantity	Carton size	Packaging material
75	14	1050	L360*W340*H300	Blister tray

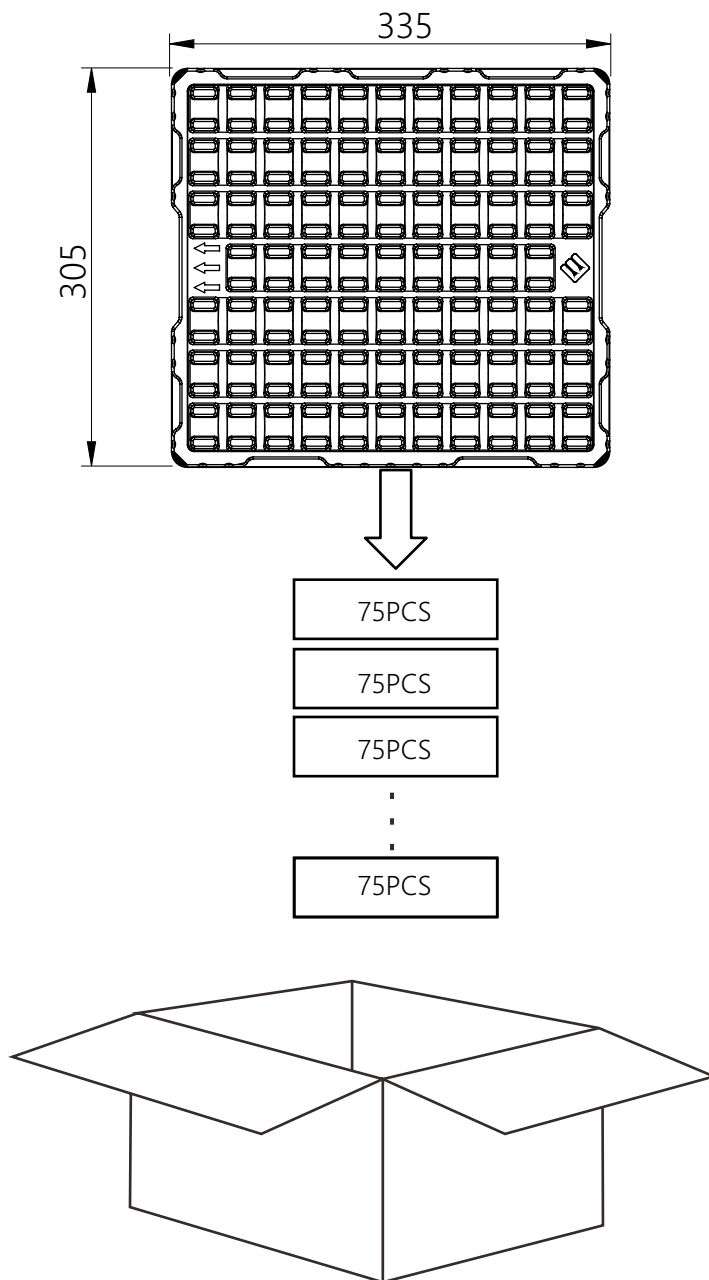

◆ Version history

date	version	change
2020.8.2	1.00	original version
2022.7.20	1.10	add number description, packaging category